

DESCRIPTION

FALCON: for normal to high mounting 11.5 ft - 23 ft (3.5 - 7 m)
FALCON XL: for low mounting 7 ft - 11.5 ft (2 - 3.5 m)

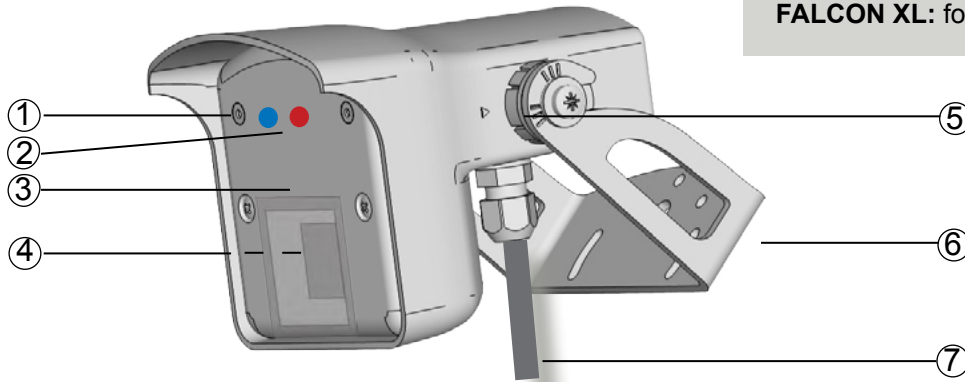

1. push buttons
2. LEDs
3. front face
4. radar antenna
5. angle indication
6. bracket
7. cable

TECHNICAL SPECIFICATIONS

Technology:	microwave doppler radar
Transmitter frequency:	24.125 GHz
Transmitter radiated power:	< 20 dBm EIRP
Transmitter power density:	< 5 mW/cm ²
Detection mode:	motion/movement
Detection zone (typical):	*FALCON: 13ft (W) x 16ft (D) @ 16ft; FALCON XL: 13ft x 6.5ft @ 8ft 2in
Min. detection speed:	** 2.2 in/s (measured in the sensor axis)
Supply voltage:	12V to 24V AC ±10%; 12V to 24V DC +30% / -10%
Mains frequency:	50 to 60 Hz
Max power consumption:	< 2 W
Output:	relay (free of potential change-over contact)
Max. contact voltage:	42V AC/DC
Max. contact current:	1A (resistive)
Max. switching power:	30W (DC) / 60VA (AC)
LED-signal:	red: detection state, parameter indication; green: value indication
Mounting height:	*FALCON: 11.5ft - 23ft; FALCON XL: 6.5ft - 11.5ft
Degree of protection:	IP65
Temperature range:	from -22F to 140F (-30 °C to + 60 °C)
Dimensions:	5 in (D) x 4 in (W) x 3 3/4 (H); (127 mm (L) x 102 mm (H) x 96 mm (W))
Tilt angles:	0° to 180° vertical
Materials:	ABS and polycarbonate
Weight:	.88lbs (400 g)
Cable length:	33 ft (10 m)
Norm conformity:	R&TTE 1999/5/EC; EMC 2004/108/EC

Specifications are subject to change without prior notice.

* Other use of this device outside its permitted purpose cannot be guaranteed by the manufacturer.

** Measured in optimal conditions

1 INSTALLATION TIPS

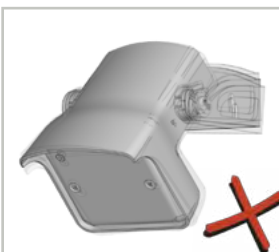

Avoid vibrations.

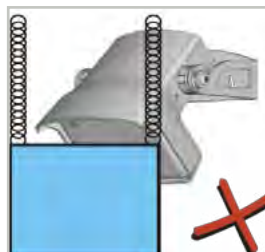

Do not cover the sensor.

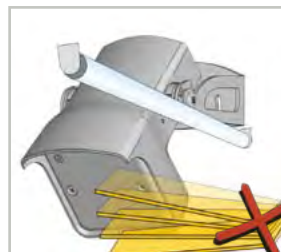

Avoid proximity to neon or fluorescent lamps or moving objects.

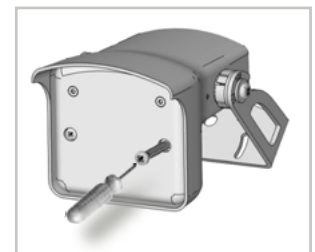

Only open the sensor when the cable needs to be replaced.

2 DIMENSIONS (INCHES)

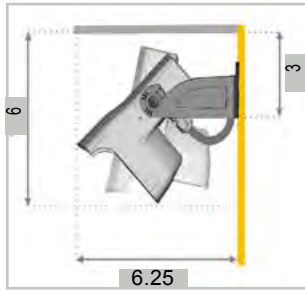

Wall mounting

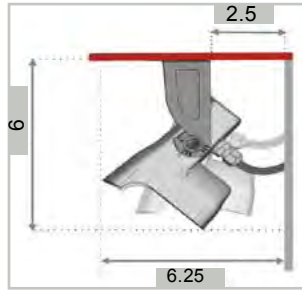

Ceiling mounting

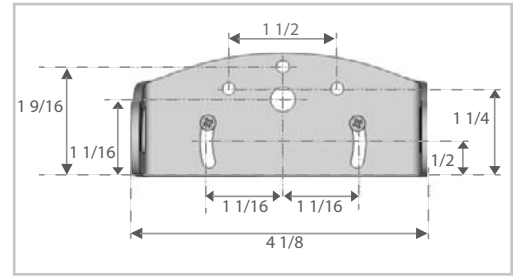

Bracket dimensions

3 POSSIBLE SETTINGS BY REMOTE CONTROL

	0	1	2	3	4	5	6	7	8	9
FIELD SIZE SENSITIVITY	XXS	XS	S	>	>	>	>	L	XL	XXL
HOLD-OPEN TIME	0.5 s	1 s	2 s	3 s	4 s	5 s	6 s	7 s	8 s	9 s
OUTPUT CONFIGURATION	n/a	A	P	n/a	n/a	n/a	n/a	A = active output (relay active with detection) P - passive output (relay active with no detection)		
DETECTION MODE	n/a	bi	uni	uni departing	n/a	n/a	n/a	bi = two-way detection uni = one-way detection towards sensor uni departing = one-way detection away from sensor		
DETECTION FILTER/ REJECTION MODE	n/a	1	2	3	4	5	6	1 - 2 = pedestrian detection 3 - 6 = Vehicle detection with pedestrian and cross traffic rejection		

= DEFAULT VALUES

RESETTING TO DEFAULT VALUES:

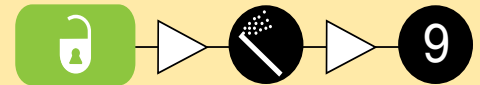

RESETTING TO DEFAULT VALUES WHERE THE SERIAL NUMBER LABEL IS MARKED WITH "RL" OR "SL":

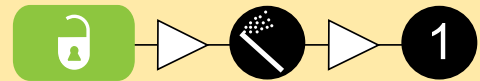

4 ACCESS CODE VIA REMOTE CONTROL

The access code (1 to 4 digits) is recommended to set sensors installed close to each other.

DELETING AN ACCESS CODE:



SAVING AN ACCESS CODE:



Once you have saved an access code, you always need to enter this code to unlock the sensor.

If you do not know the access code, cut and restore the power supply. Within 1 minute, you can access the sensor without introducing any access code.

5 POSSIBLE SETTINGS BY PUSH BUTTONS

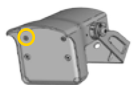

TO START OR END AN ADJUSTMENT SESSION, press and hold either push button until the LED flashes or stops flashing.

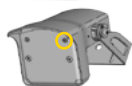

TO SCROLL THROUGH THE PARAMETERS, press the right push button.

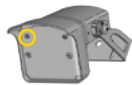

TO CHANGE THE VALUE OF THE CHOSEN PARAMETER, press the left push button.

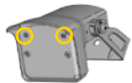

To restore the factory settings, hold down both buttons until both LEDs blink

	Parameter number (Red LED)	Value (Green LED)	Default values
1	FIELD SIZE/SENSITIVITY	●●●●●●●● (7)	(7)
2	HOLD-OPEN TIME	n/a	(0)
3	OUTPUT CONFIGURATION	●●●●●●●● (1)	(1)
4	DETECTION MODE	●●●●●●●● (2)	(2)
5	DETECTION FILTER REJECTION MODE	●●●●●●●● (1)	(1)

6 MOUNTING & WIRING

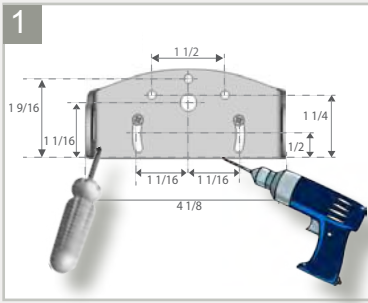

Remove the bracket from the sensor. Drill 2 holes accordingly. Afix the bracket firmly.



Position the sensor on the bracket and fasten the screws firmly.

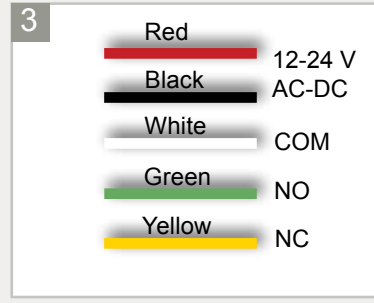

Connect the wires to the door controller. Choose between NO and NC contact.

7 DETECTION FIELD ADJUSTMENTS

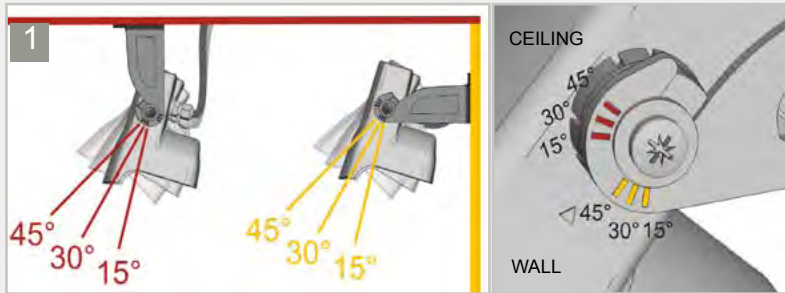

Adjust the angle of the sensor to position the detection field.

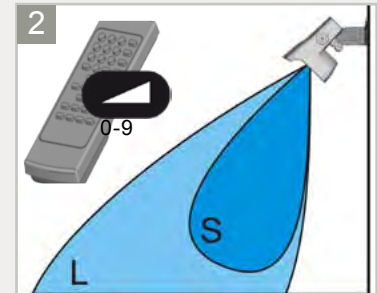

Adjust the field size with the remote control or the push buttons.

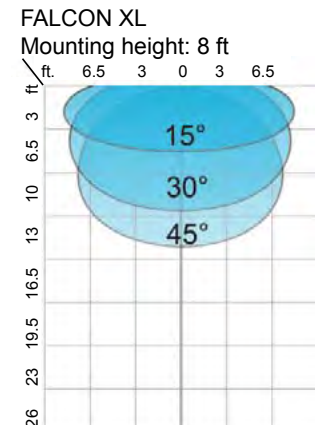
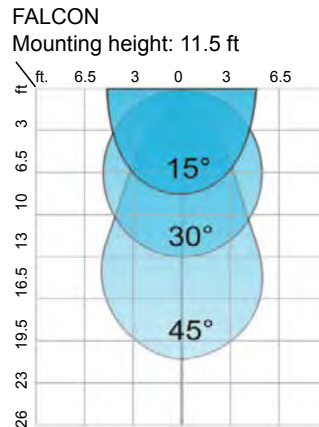
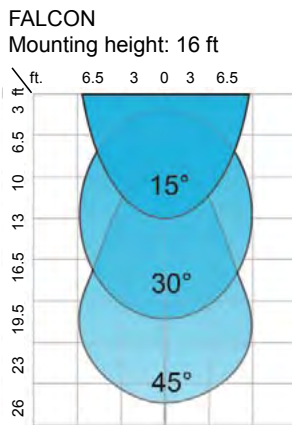

All detection field dimensions were measured in optimal conditions and with field size value 9.

8 DETECTION FILTER - PEDESTRIAN REJECTION - VEHICLE DETECTION

Choose the right detection filter for your application with the remote control or the push buttons:



1-6

Detection of all targets
(pedestrians and parallel traffic are detected)

1 = no specific filter

2 = filter against disturbances
(recommended in case of vibrations,
rain etc.)



Detection only of vehicles moving towards the sensor*
(pedestrians and parallel traffic are not detected + disturbances are filtered)

Value recommendations according to angle and height:







	23 ft	16 ft	11.5 ft	8 ft
15°	3	3	3	3
30°	4	4	4	4
45°	5	5	5	4
> 45°	6	6	6	5

XL

Always check if the chosen value is optimal for the application. The object approach angle, speed, size and nature can influence it's detection.

* The vehicle detection filter increases the response time of the sensor.

9 TROUBLESHOOTING

	The door remains closed. The LED is OFF.	The sensor power is off.	1 Check the wiring and the power supply.
	The door does not react as expected.	Improper output configuration on the sensor.	1 Check the output configuration setting on each sensor connected to the door operator.
	The door opens and closes constantly.	The sensor is disturbed by the door motion or vibrations caused by the door motion.	1 Make sure the sensor is affixed properly. 2 Make sure the detection mode is unidirectional. 3 Increase the tilt angle. 4 Increase the detection filter value. 5 Reduce the field size.
	The door opens for no apparent reason.	The sensor detects raindrops or vibrations.	1 Make sure the detection mode is unidirectional. 2 Increase the detection filter value.
		In highly reflective environments, the sensor detects objects outside of its detection field.	1 Change the antenna angle. 2 Decrease the field size. 3 Increase the detection filter value.
	The vehicle detection filter is used, but pedestrians are still detected.	The chosen value is not optimal for this application.	1 Increase the detection filter value. 2 Decrease the sensor angle. 3 Increase the installation height. 4 Check and verify you have the correct Falcon determined by mounting height.
	The LED flashes quickly after unlocking.	The sensor needs an access code to unlock.	1 Enter the correct access code. 2 If you do not know the access code, cut the power supply and restore it to access the sensor and change the access code or delete it.
	The sensor does not respond to the remote control.	The remote control batteries are weak or improperly installed.	1 Check the batteries and change them if necessary.

SAFETY INSTRUCTIONS

The manufacturer of the door system and/or installer is responsible for carrying out a risk assessment and installing the sensor and the door system in compliance with applicable national and international regulations and standards on door safety. Only trained and qualified personnel may install and setup the sensor. The warranty is void if unauthorized repairs are made or attempted by unauthorized personnel.

10 ACCESSORIES

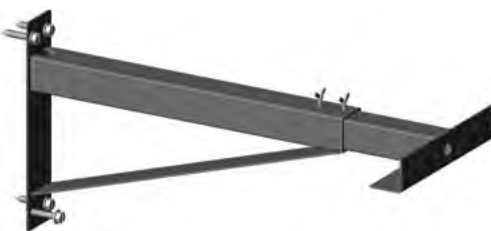

Industrial Mounting bracket.
Adjustable 20 - 36 inches.
P/N: 10HDBRACKET

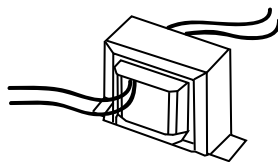

24VAC 40VA Transformer
P/N: 1024VAC

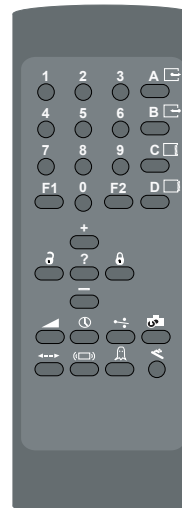

Remote control
P/N: 10REMOTE

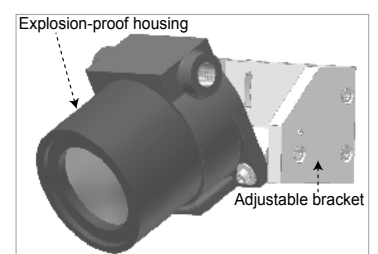

Explosion-proof Falcon
P/N: 10FALCONEX,
10FALCONEXXL

11 COMPANY CONTACT



Do not leave problems unresolved. If a satisfactory solution cannot be achieved after troubleshooting a problem, please call BEA, Inc. If you must wait for the following workday to call BEA, leave the door inoperable until satisfactory repairs can be made. Never sacrifice the safe operation of the automatic door or gate for an incomplete solution.

Our Service Technicians can be called 24 hours a day, 7 days a week. For more information visit www.beasensors.com.

For email support contact us at: Tech_Services@beainc.com			
Phone: 1-800-523-2462		Fax: 1-888-523-2462	
After Normal Business Hours			
West / Mexico 1-888-419-2564	Central 1-800-407-4545	AK, MI, WI, TX, Canada 1-866-836-1863	East 1-866-249-7937